

P/N UE66-X04-1X50

ASSEMBLED PLUG  
(REF. ONLY)

**AMPHENOL PART NUMBER CONFIGURATION**

INFINITY  
RoHS PLUG KIT

PCB OPTIONS  
C = NO INSERT AND NO PCB  
E = 1.27µm GOLD NO PCB  
N = 1.27µm GOLD WITH PCB

CABLE TYPE  
04 = 4X

CABLE SIZE  
1 = 24 AWG WIRE  
2 = 26/28 AWG WIRE (SEE NOTE 2)

KEYING  
0 = ALL KEY SLOTS  
(STANDARD)

MOUNTING STYLE  
1 = LANYARD LATCH  
24 AWG CABLE ONLY  
3 = LOW PROFILE LANYARD LATCH  
26/28 AWG CABLE ONLY  
(SEE NOTE 2)  
5 = LANYARD LATCH - NO LOGO  
24 AWG CABLE ONLY

FERRULE  
0 = NO FERRULE  
1 = WITH FERRULE

**MATERIAL:**  
PLASTIC INSERT:  
HIGH TEMPERATURE RESISTANT NYLON FLAMMABILITY RATING UL94V-0  
CONTACTS:  
COPPER ALLOY  
BACK SHELL:  
DIE CASTING

**PLATING:**  
CONTACTS:  
1.27µm [50µ"] MIN GOLD OVER 1.27µm [50µ"] MIN NICKEL ON CONTACT SURFACES. GOLD FLASH OVER 1.27µm [50µ"] MIN NICKEL ON CONTACT TAILS.  
BACK SHELL:  
2.54µm [150µ"] MIN NICKEL  
TEMPERATURE RANGE: -40C TO +85C

REVISIONS				
REV.	ECN/ROUTING NO.	DESCRIPTION	DATE	APPROVED
A		PROPOSAL	2005/10/25	A.G.
B		PROPOSAL	JUNE06/07	A.G.

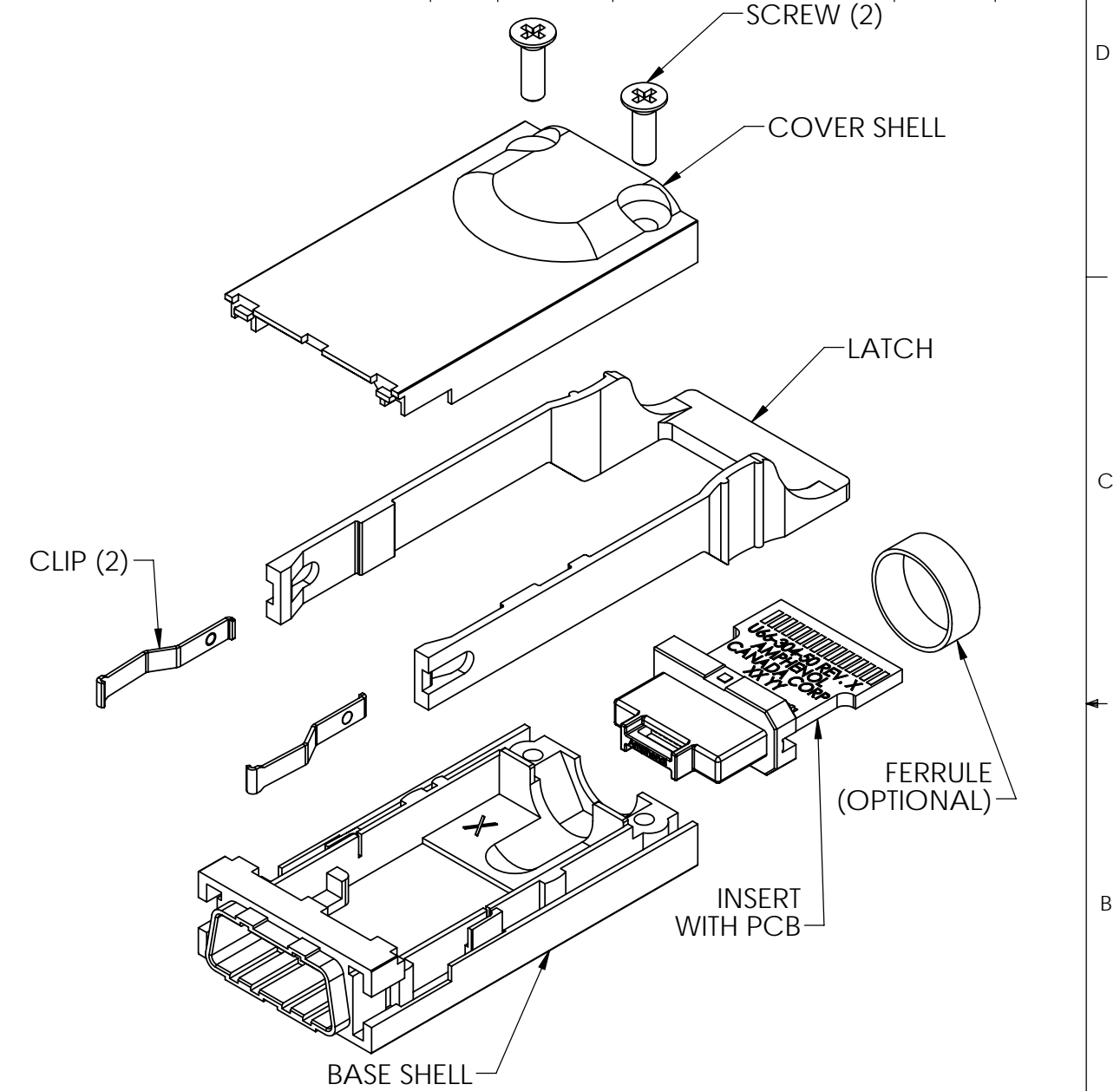

- NOTES:
- DIMENSION FOR LOW PROFILE (26/28 AWG) SHELL IS 12.00 mm [0.472"] HIGH.
  - REQUIREMENT TO BUILD UP 28 AWG WIRE.



UNLESS OTHERWISE SPECIFIED DIMENSIONS ARE IN MILLIMETERS TOLERANCES ARE:		APPROVALS		DATE	Amphenol Canada Corp.	
DECIMALS	ANGLES	DRAWN	M.LONG	2005/10/24	TITLE	
X.X ± 0.15	± 1°	DESIGNED	M.LONG	2005/10/24	INFINIBAND 4X PLUG KIT, LANYARD LATCH STYLE, RoHS	
X.XX ± 0.10		CHECKED	J.SI	2005/10/25		
MATERIAL AND FINISH		QA APPD				
N/A		IE APPD			SIZE	DWG. NO.
REF.		DWG APPD		A.GREEN	A3	P-UE66-X04-XXX0
CODE IDENT. NO.	03554	DATE		2005/10/25	SCALE	1 = 1
				PROJECT	SHEET 1 OF 1	
				REV.	B	